

Terahertz time-domain spectroscopy of submonolayer water adsorption in hydrophilic silica aerogel

Jiangquan Zhang and Daniel Grischkowsky

School of Electrical and Computer Engineering, Oklahoma State University, Stillwater, Oklahoma 74078

Received October 24, 2003

We report a terahertz time-domain spectroscopy study of the adsorption of water in hydrophilic silica aerogel. The adsorbed water is in submonolayer form and shows properties of index of refraction similar to those of bulk water but different absorption properties. © 2004 Optical Society of America
OCIS codes: 300.6490, 320.7150.

Silica aerogels are remarkable artificial materials combining low density, low thermal conductivity, low index of refraction, high transparency, and extremely high surface area.¹ They consist of a fractal structure of relatively uniform silica strands typically 3 nm in diameter. This structure results in their open ultrasmall interconnected pores, providing access to the entire surface area for the reaction or deposition of materials. Consequently, silica aerogels are an excellent substrate for use in studying the properties of submonolayer adsorbed molecules.

In this Letter we report a terahertz time-domain spectroscopy (THz-TDS) study of the adsorption of water in hydrophilic silica aerogel.²⁻⁴ The adsorbed water is in submonolayer form and shows properties of index of refraction similar to those of bulk water but different absorption properties. Figure 1 shows the experimental setup of the broadband THz-TDS system, which consists of a THz transmitter and receiver, along with beam-shaping and steering components.⁵ The THz pulse is generated and detected by photoconductively switching the transmitter and receiver by 40-fs optical pulses from a Ti:sapphire laser. Between the paraboloidal mirrors is a cylindrical vacuum chamber of 188 mm (length) \times 80 mm (diameter), with two 50 mm (diameter) \times 10 mm (thickness) silicon windows for the THz beam to pass through. The entire setup is placed in an airtight enclosure purged with dry air. The hydrophilic silica aerogel sample, with dimensions of 50.0 mm \times 49.3 mm \times 12.1 mm and weight of 2.65 g, is centered perpendicular to the THz beam path in the middle of the vacuum chamber. Obtained from MarkeTech International, this lightweight transparent solid has an enormous surface area per weight of 800 m²/g, corresponding to a total surface area of 2120 m².

As in other THz-TDS studies,⁵ a reference pulse and a signal pulse were measured in the time domain, and the complex spectra were obtained through digital fast Fourier transformation of the THz electrical pulses. In this experiment the reference was the measured pulse transmitted through the sample when the chamber was pumped out and kept below 10 mTorr. After this scan the vacuum chamber was filled with 18 Torr of water vapor at room temperature, and the aerogel was allowed to equilibrate for approximately 1 h. The signal pulse was then measured. The measured refer-

ence and signal pulses are presented in Fig. 2(a), where the reference pulse has been shifted for clarity. The respective spectra are shown in Fig. 2(b). The sharp absorption lines in the signal spectrum are the characteristic lines of water vapor; the broadband signal drop is due to the adsorbed water inside the aerogel. The inset of Fig. 2(a) is the enlargement of the main peaks of the time-domain pulses, which shows that the signal pulse is delayed by approximately 0.16 ps (with an estimated error of ± 0.02 ps) relative to the reference pulse, caused by both the adsorbed water inside the aerogel and the water vapor outside the aerogel.

To estimate the delay caused by the adsorbed water and to reduce the effect of the sharp absorption lines of water vapor in the analysis of the measurement, we conducted the same experiment with the aerogel sample removed from the vacuum chamber. The reference pulse was obtained with the vacuum chamber pumped out, and the signal scan was measured with the chamber filled with 18 Torr of water vapor at room temperature. The measured pulses showed that the signal scan is delayed by approximately 0.08 ± 0.02 ps because of the water vapor, while their corresponding spectra differed only by the strong absorption of the water vapor lines.

With this result the delay caused by the adsorbed water in the aerogel experiment is then obtained as $\Delta t = 0.08 \pm 0.03$ ps. We assume that the index of refraction of the adsorbed water is the same as that of the bulk water. The equivalent water layer thickness can then be calculated as $L = c\Delta t / (n_w - 1) = 19 \pm 8 \mu\text{m}$, where c is the speed of light in vacuum and $n_w = 2.27$ is the index of refraction of bulk water at 0.5 THz,⁶⁻⁸ the frequency of the peak spectral amplitude. Given

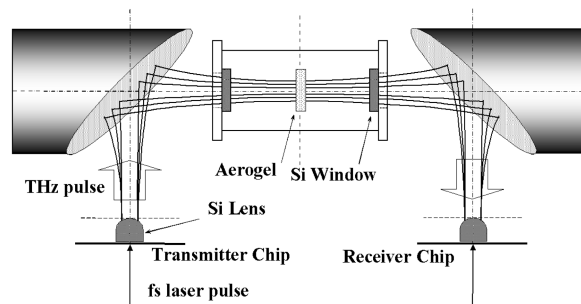

Fig. 1. Experimental setup.

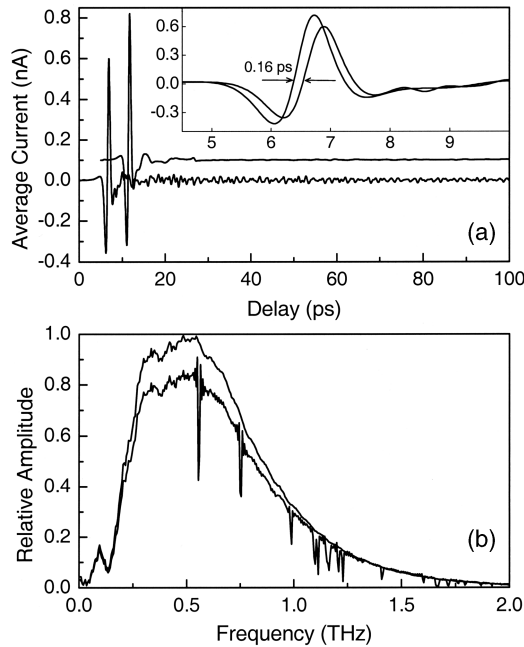

Fig. 2. (a) Output pulses of reference (top trace) and signal scans and (b) their respective spectra. The reference and signal scans have been shifted in time and separated vertically for clarity. Inset, enlargement of the pulses in the vicinity of the peaks to show the relative signal pulse delay.

this equivalent water layer thickness, and the total surface area of 2120 m^2 inside the aerogel, the surface water layer thickness can be calculated as $\Delta l = 0.022 \pm 0.008 \text{ nm}$, corresponding to 0.07 ± 0.03 monolayer thickness of water. This simple calculation shows that, on the silica aerogel surfaces, the adsorbed water is in submonolayer form. As an independent check on this value of the equivalent water layer thickness, we relocated our sample onto a battery-powered electronic balance with 2-mg sensitivity that was in a larger vacuum chamber. The addition of 18 Torr of water vapor to the chamber caused the weight of the sample to increase monotonically by $70 \pm 15 \text{ mg}$ within 1 h. This additional weight was due to the adsorbed water, which corresponds to the equivalent water layer thickness of $28 \pm 6 \mu\text{m}$, somewhat higher than the previous measurement.

The complex spectrum of the signal pulse of aerogel sample, with both the adsorbed water inside and the water vapor outside, can be calculated as

$$A_{a+aw+v}(\omega) = A_0(\omega)H_{a+aw}(\omega)H_v(\omega). \quad (1)$$

For the aerogel sample with the vacuum chamber pumped out this relation is $A_a(\omega) = A_0(\omega)H_a(\omega)$, where ω is the angular frequency, $A_0(\omega)$ is the complex spectrum of the vacuum reference pulse without aerogel sample, and $H(\omega)$ represents the complex frequency transfer functions for different conditions. The subscripts a , aw , and v stand for aerogel, adsorbed water, and water vapor, respectively, so $H_{a+aw}(\omega)$ is the complex frequency transfer function

of the aerogel with adsorbed submonolayer water, and so on. Correspondingly, the complex spectrum of water vapor in the chamber without silica aerogel can be written as $A_v(\omega) = A_0(\omega)H_v(\omega)$. Here we assume that $H_v(\omega)$ is the same with and without the aerogel in the chamber. From the equations above it is easy to extract the effect caused by the adsorbed water in the aerogel sample as

$$H_{aw}(\omega) = \frac{H_{a+aw}(\omega)}{H_a(\omega)} = \frac{A_{a+aw+v}(\omega)}{A_a(\omega)} \frac{A_0(\omega)}{A_v(\omega)}. \quad (2)$$

Figure 3(a) shows the amplitude ratio of $A_{a+aw+v}(\omega)/A_v(\omega)$ compared with $H_{aw}(\omega)$ based on Eq. (2); the respective phases are shown in Fig. 3(b). It can be seen that most of the effect of water vapor is removed after this treatment.

One of the advantages of the coherent THz-TDS system is that the time-domain scans contain both the phase and the amplitude information on the pulses, so one can simultaneously retrieve both the index of refraction and the power absorption coefficient of a sample of known thickness. In our case, however, it is impractical to measure the thickness of the adsorbed water sample inside the aerogel, as the aerogel itself is used as the reference. To obtain the absorption coefficient, it is necessary to get a more precise estimation of the equivalent sample thickness of bulk water for the adsorbed water. By use of the transfer function obtained from Eq. (2), the index of refraction $n_{aw}(\omega)$ and the power absorption coefficient $\alpha_{aw}(\omega)$ of the equivalent water layer of thickness d are defined by the relation

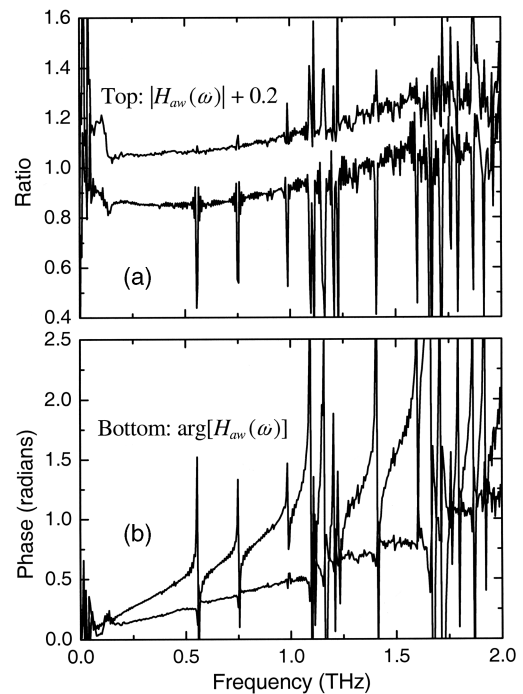

Fig. 3. (a) Amplitudes and (b) phases of $A_{a+aw+v}(\omega)/A_a(\omega)$ compared with $H_{aw}(\omega)$ based on Eq. (2). The amplitude of $H_{aw}(\omega)$ has been raised by 0.2 for clarity.

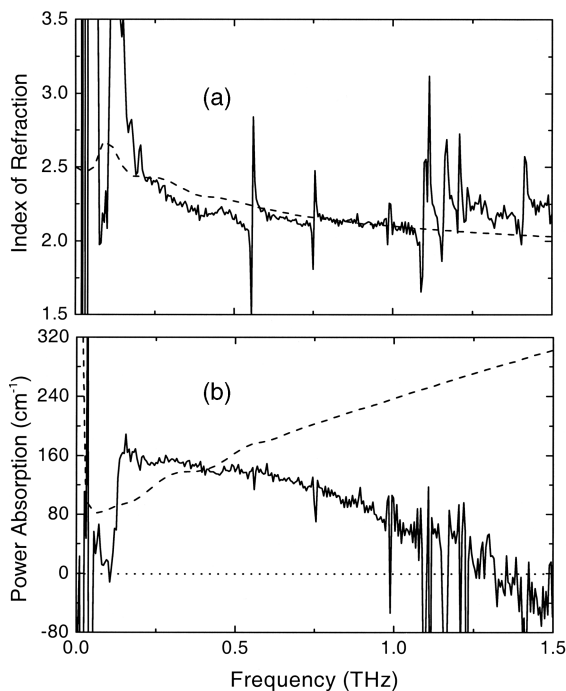

Fig. 4. (a) Index of refraction and (b) power absorption coefficient $\alpha_{aw}(\omega)$ due to the adsorbed water inside the silica aerogel. The dashed curves are those of the bulk water.

$$H_{aw}(\omega) \equiv \exp\left[i \frac{2\pi d}{\lambda_0} [n_{aw}(\omega) - 1]\right] \exp[-\alpha_{aw}(\omega)d/2], \quad (3)$$

where λ_0 is the free-space wavelength. In the calculation we adjust the layer thickness d to match the index of refraction with a precision of ± 0.05 to that of bulk water in the range 0.75–0.99 THz between the absorption peaks of water vapor. By this procedure the equivalent water layer thickness is obtained as $d = 21 \pm 1 \mu\text{m}$, in reasonable agreement with the lower-precision earlier estimates of $19 \pm 8 \mu\text{m}$ based on relative pulse delay, and that of $28 \pm 6 \mu\text{m}$ determined by the weight increase of the aerogel when exposed to water vapor.

The change in the power absorption of the aerogel sample caused by the adsorbed water is then calculated as presented in Fig. 4(b), together with the index of refraction in Fig. 4(a), as well as those for bulk water.⁸ It is worth pointing out that, in a usual absorption calculation, the Fresnel transmission coefficient has to be obtained for a real sample with abrupt interfaces and a definite thickness. However, in our case this correction is not made, since our sample of adsorbed water does not present abrupt interfaces. In Fig. 4(a), the obtained index of refraction of adsorbed water shows the remnants of the water vapor absorption lines, which could not be completely removed by Eq. (2). However, the overall results indicate that the

adsorbed submonolayer water has an index of refraction similar to that of bulk water.

The change in the transmitted power through the aerogel appears to show two effects; first an increase in absorption due to the adsorbed water itself and second, starting at ~ 1 THz and increasing with frequency, a decrease in absorption as a result of the adsorbed water passivating the hydrophilic Si–OH groups.⁹ Our unpublished THz-TDS comparison (in vacuum) between the hydrophilic aerogel sample above and a hydrophobic sample shows essentially the same absorption up to 1 THz. Thereafter, the absorption of the hydrophilic sample increases more rapidly with frequency; at 1.5 and 2.0 THz the hydrophilic absorption coefficient is 1.29 and 1.56 times larger, respectively, than that of the hydrophobic sample.

As shown in Fig. 2(b), in the frequency range from 0.25 to 1.0 THz, a significant amplitude drop as a result of absorption is observed for the signal scan. However, at 1.25 THz, the signal amplitude is almost the same as the reference signal, indicating little absorption as a result of the adsorbed water. In Fig. 4(b) the resulting $\alpha_{aw}(\omega)$ is completely different from that of the bulk water, for which the power absorption increases monotonically with frequency. The apparent negative absorption seen above 1.25 THz is considered to be due to the adsorbed water passivating the hydrophilic Si–OH group. These remarkable changes in the far-infrared absorption of silica aerogel caused by the submonolayer of adsorbed water await theoretical explanation.

This investigation shows the feasibility of using silica aerogel as the adsorbing medium in studies of the far-infrared properties caused by the adsorbed material. The large surface area greatly increases measurement sensitivity.

This work was partially supported by the National Science Foundation, the U.S. Army Research Office, and the U.S. Department of Energy. D. Grischkowsky's e-mail address is grischd@ceat.okstate.edu.

References

1. S. S. Kistler, *J. Phys. Chem.* **36**, 52 (1932). An overview of the properties of aerogels is available at <http://eande.lbl.gov/ecs/aerogels/>.
2. G. J. Young, *J. Colloid Sci.* **13**, 67 (1958).
3. A. da Silva, P. Donoso, and M. A. Aegerter, *J. Non-Cryst. Solids* **145**, 168 (1992).
4. M. A. Henderson, *Surf. Sci. Rep.* **46**, 1 (2002).
5. D. Grischkowsky, S. Keiding, M. van Exter, and Ch. Fattinger, *J. Opt. Soc. Am. B* **7**, 2006 (1990).
6. L. Thrane, R. H. Jacobsen, P. Uhd Jepsen, and S. R. Keiding, *Chem. Phys. Lett.* **240**, 330 (1995).
7. J. T. Kindt and C. A. Schmuttenmaer, *J. Phys. Chem.* **100**, 10373 (1996).
8. J. Dai and D. Grischkowsky, unpublished measurement of bulk water in our laboratory.
9. P. B. Wagh and S. V. Ingale, *Ceramics Int.* **28**, 43 (2002).