

Efficient generation of 380 fs pulses of THz radiation by ultrafast laser pulse excitation of a biased metal-semiconductor interface

N. Katzenellenbogen and D. Grischkowsky
 IBM Watson Research Center, P. O. Box 218, Yorktown Heights, New York 10598

(Received 10 September 1990; accepted for publication 12 November 1990)

We have demonstrated a new method of generating pulses of freely propagating THz electromagnetic radiation. The resulting 380 fs pulses are the shortest directly measured THz pulses in free space to date and are more powerful than those generated by Hertzian dipoles or by resonant dipole antennas. Temporal features as short as 190 fs were observed on these THz radiation pulses and thereby, illustrate an ultrafast receiver response time.

Recently, there has been a great deal of work demonstrating the generation of THz radiation via excitation with ultrashort laser pulses. Modern integrated circuit techniques have made possible the precise fabrication of micron-sized dipoles, which when photoconductively driven by subpicosecond laser pulses can radiate well into the THz regime.^{1,2} An alternative and complementary approach has been to extend radio and microwave techniques into the THz regime through the use of antennas.³⁻⁹ Other sources based on various physical systems and effects include the emission of an electromagnetic shock wave due to a moving volume dipole distribution, i.e., electro-optic Cherenkov radiation,^{10,11} and the electromagnetic shock wave radiated by a propagating surface-dipole distribution.^{12,13} Most recently, radiation has been generated by photoconductively driving the surface field of semiconductors^{14,15} and of strained-layer superlattices¹⁶ with ultrafast laser pulses.

In this letter we report a new mechanism of generating relatively powerful and extremely short pulses of freely propagating THz radiation. After propagating 88 cm in free space, these pulses were measured to have a (full width at half maximum) pulse width of 380 fs with no deconvolution. These are the shortest directly measured, freely propagating THz pulses in free space to date. This source is fully compatible with our recently developed optoelectronic THz beam system^{8,9} and has thereby extended the frequency bandwidth of this system to beyond 3 THz. The THz pulse amplitudes are larger than those produced with our previously used antenna geometry.⁹ Because of the ultrafast temporal features of these radiation pulses, we have been able to demonstrate that our ion-implanted, silicon-on-sapphire receiver can resolve features as short as 190 fs.

The source is based on a recently discovered optoelectronic effect,¹⁷ initially used to generate a 350 fs electrical pulse on a coplanar transmission line by focusing an ultrashort laser pulse on the interface (edge) of a positively biased line. Here, we use the same technique with a different line geometry and an experimental arrangement designed to capture the radiation emitted into the substrate from the point of excitation.

The configuration used to generate the pulses of freely propagating THz electromagnetic radiation is shown in Fig. 1(a), where the coplanar transmission line structure

consists of two 10- μm -wide metal lines separated by 80 μm . The length of the entire transmission line is 20 mm, and the laser excitation spot with a diameter of typically 10 μm was located at the midpoint. This structure was fabricated using standard liftoff procedures on silicon-on-sapphire (SOS), GaAs, and InP intrinsic, high-resistivity wafers. For the SOS wafers the initial metal layer consists of 100 nm of Ti followed by 500 nm of Al. After liftoff this gave a resistivity of 10 Ω/mm for a single 10- μm -wide line. For both GaAs and InP, the metallization consisted of 5 nm of Ni followed by 10 nm of Ge followed by 80 nm of Au followed by 10 nm of Ge followed by 30 nm of Ni followed by 100 nm of Au. After this deposition the wafer was given a standard anneal to form an Ohmic contact. Liftoff was then performed. This procedure gave a resistivity of 120 Ω/mm for a single 10- μm -wide line.

Irradiating the metal-semiconductor interface (edge) of the positively biased line with focused ultrafast laser

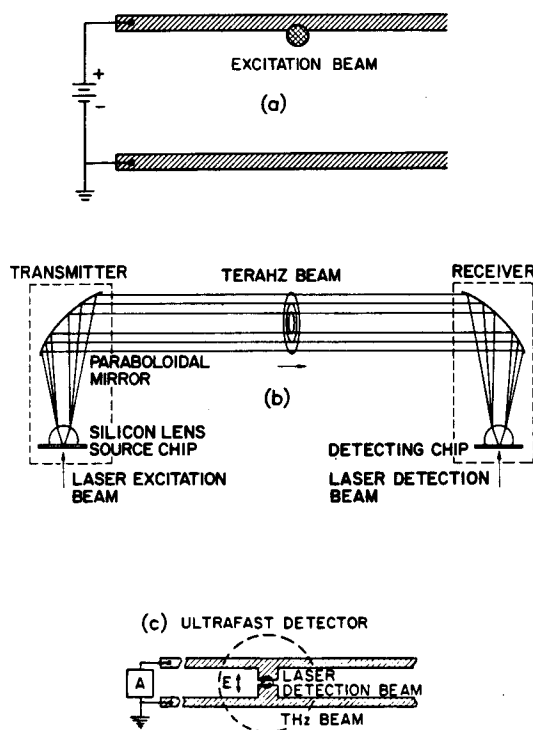

FIG. 1. (a) Configuration used to generate the freely propagating pulses of THz radiation. (b) THz collimating and focusing optics. (c) Receiving antenna geometry.

pulses produces synchronous bursts of electromagnetic radiation. A colliding-pulse mode-locked (CPM) dye laser provides the 623 nm, 50 fs excitation pulses at a 100 MHz repetition rate in a beam with an average power of 7 mW at the excitation spot. A large fraction of the laser generated burst of THz radiation is emitted into the substrate in a cone normal to the interface and is then collected and collimated by a high-resistivity (10 k Ω cm) crystalline silicon lens attached to the back side of the chip.^{2,8,9,18} The entire THz optical arrangement is illustrated in Fig. 1(b). After collimation by the lens, the THz beam propagates and diffracts to a paraboloidal mirror, where the THz radiation is recollimated into a highly directional beam. After further propagating 50 cm the THz beam is incident upon the receiver, where a second matched paraboloidal mirror focuses the beam onto a second identical silicon lens, which in turn focuses it onto an ion-implanted SOS detection chip with the antenna geometry shown in Fig. 1(c). The 20- μ m-wide antenna structure is located in the middle of a 20-mm-long coplanar transmission line consisting of two parallel 5- μ m-wide aluminum lines separated from each other by 10 μ m. The electric field of the focused incoming THz radiation induces a transient bias voltage across the 5 μ m gap between the two arms of this receiving antenna, directly connected to a low-noise current amplifier. The amplitude and time dependence of this transient voltage are obtained by measuring the collected charge (average current) versus the time delay between the THz pulses and the CPM laser pulses. These pulses in the 5 mW detection beam synchronously gate the receiver, by driving the photoconductive switch defined by the 5 μ m antenna gap.

The measured THz pulse emitted from the laser excited metal-GaAs interface with +60 V bias across the transmission line is shown in Fig. 2(a), and on an expanded time scale in Fig. 2(b). The numerical Fourier transform of the pulse of Fig. 2(a) is presented in Fig. 2(c). The measured pulse width with no deconvolution is seen to be 380 fs. The pulse shape is somewhat similar to that observed earlier from a 30 μ m transmitting antenna on ion-implanted SOS, where the measured pulse width was 540 fs.⁹ This pulse shape is indicative of a short current pulse generating the THz radiation. The high-frequency, low-amplitude oscillations observed after the main pulse are the coherent transients emitted during the free-induction decay of the residual water vapor excited by the passage of the THz pulse.¹⁹

The feature (dip) on the falling edge of the THz pulse shown in Fig. 2 is the sharpest feature ever measured with an ion-implanted, SOS detector. The measured 190 fs time delay from the minimum of the dip to the next later maximum demonstrates an exceptionally fast receiver response time. This ultrafast response time is surprising when compared with the earlier optical measurement²⁰ of the limiting carrier lifetime of 600 fs for ion-implanted SOS. However, the response time in the case described here is mainly determined by the rise time of the photocurrent in the receiving antenna and is not limited by the carrier lifetime. An analysis of our own recent measurements with a com-

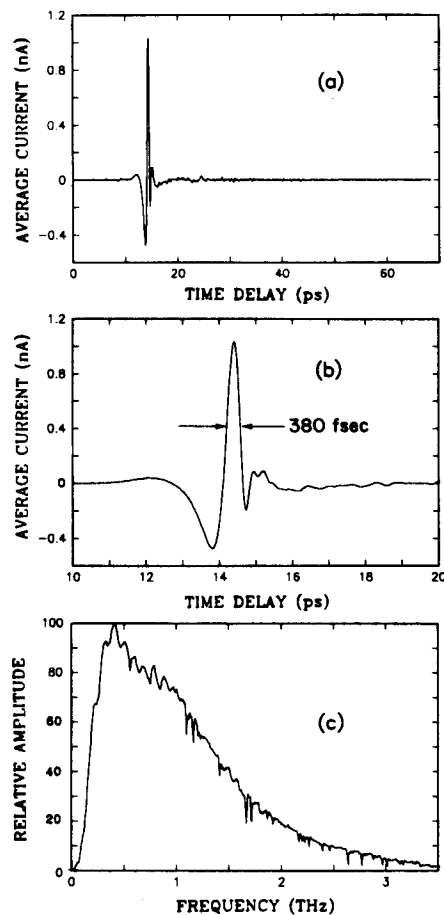

FIG. 2. (a) Measured THz pulse. (b) Measured THz pulse on an expanded time scale. (c) Amplitude spectrum of the THz pulse.

pletely symmetrical system having an ion-implanted SOS transmitter with the same antenna as for the above receiver shows this rise time to be faster than 200 fs.

The sharp feature is caused by the pulse reshaping due to the propagation of the ultrashort THz pulse through the 0.46-mm-thick GaAs generation chip and the 0.46-mm-thick sapphire detection chip, both of which are dispersive.¹⁸ This conclusion has been confirmed by propagating such pulses through an additional 0.5-mm-thick sapphire plate and observing the feature to deepen significantly together with the appearance of additional oscillations. In addition, a numerical calculation of the effect of propagating these pulses through a material with an opposite dispersion and "absorption" showed the feature to almost disappear. Because of the exceptionally low dispersion (and absorption) of silicon,¹⁸ the 13.5 mm propagation through the silicon lenses is considered not to significantly affect the pulse shape.

This radiation process is comparatively powerful. At +60 V the observed 1.0 nA signal is comparable to the 1.5 nA signal obtained from our typical antenna structure fabricated on ion-implanted SOS.^{8,9} However, the earlier value of 1.5 nA was obtained with a 30- μ m-long receiving antenna, which gives three times the current of the 10- μ m-long antenna used here. Thus, the radiated signal is approximately twice as large that from the earlier source.⁹

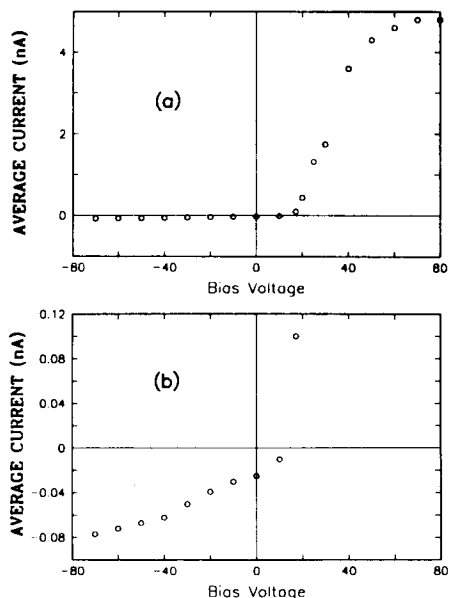

FIG. 3. (a) Measured THz pulse amplitude vs bias voltage across the transmission line as illustrated in Fig. 1(a). (b) Measured THz pulse vs bias voltage on an expanded amplitude scale.

This point is illustrated by the 4.5 nA measurements shown in Fig. 3 which were obtained with a 50- μ m-long antenna.

Quite different results with interface excitation were obtained from InP and unimplanted SOS substrates. For InP the emission of radiation from the metal-semiconductor interface was essentially absent; the observed signal was less than 1/100 of that obtained from GaAs. For SOS, 600 fs radiation pulses were observed with amplitudes 1/4 that of the signal from GaAs. The voltage dependence of the SOS signal was similar to that of GaAs described below.

For GaAs the measured dependence of the THz pulse amplitude versus the applied bias voltage is displayed in Fig. 3, where the asymmetry between positive and negative bias is particularly noticeable. For additional sensitivity and lower noise,⁹ these data were taken with a 50- μ m-long receiving antenna. For comparable negative bias the signal strength is typically reduced by more than 70 times compared to a positive bias. For negative bias the pulse shape is inverted but is otherwise not changed, and the pulse amplitude increases approximately linearly with voltage up to -80 V. For positive bias above the relatively sharp turn-on voltage of approximately 20 V the measured signal increases linearly with voltage up to 40 V and from then monotonically up to a saturation value of approximately 60 V. This type of dependence was observed in the initial

discovery of the interface effect,¹⁷ with respect to pulse generation on transmission lines. Recent work has measured the effect of voltage on the Schottky barrier at a metal/GaAs interface, by monitoring the generation of THz radiation due to the surface field,¹⁵ and a much weaker dependence was observed.

The newly extended frequency range from low frequencies up to 3 THz illustrated in Fig. 2(c) is immediately useful for time-domain spectroscopy.¹⁸ This is apparent from a close examination of Fig. 2(c), where essentially all of the sharp line structure is due to water lines¹⁹ from the residual water vapor present in the relatively long 88 cm path of the THz pulse. Spectral features can be clearly resolved out to 3 THz.

We acknowledge stimulating and informative conversations with Stephen Ralph and Joshua Rothenberg. Some early preliminary measurements were made by Søren Keiding. The excellent masks and wafer fabrications were done by Hoi Chan.

- ¹D. H. Auston, K. P. Cheung, and P. R. Smith, *Appl. Phys. Lett.* **45**, 284 (1984).
- ²Ch. Fattinger and D. Grischkowsky, *Appl. Phys. Lett.* **53**, 1480 (1988); **54**, 490 (1989).
- ³G. Mourou, C. V. Stancampiano, A. Antonetti, and A. Orszag, *Appl. Phys. Lett.* **39**, 295 (1981).
- ⁴R. Heidemann, Th. Pfeiffer, and D. Jager, *Electron. Lett.* **19**, 317 (1983).
- ⁵A. P. DeFonzo, M. Jarwala, and C. R. Lutz, *Appl. Phys. Lett.* **50**, 1155 (1987); **51**, 212 (1987).
- ⁶Y. Pastol, G. Arjavalingam, J-M. Halbout, and G. V. Kopcsay, *Electron. Lett.* **24**, 1318 (1988).
- ⁷P. R. Smith, D. H. Auston, and M. C. Nuss, *IEEE J. Quantum Electron.* **24**, 255 (1988).
- ⁸M. van Exter, Ch. Fattinger, and D. Grischkowsky, *Appl. Phys. Lett.* **55**, 337 (1989).
- ⁹M. van Exter and D. Grischkowsky, *IEEE Trans. Microwave Theory Tech.* **38**, 1684 (1990).
- ¹⁰D. H. Auston, *Appl. Phys. Lett.* **43**, 713 (1983).
- ¹¹B. B. Hu, X.-C. Zhang, and D. H. Auston, *Appl. Phys. Lett.* **56**, 506 (1990).
- ¹²D. Grischkowsky, I. N. Duling, III, J. C. Chen, and C.-C. Chi, *Phys. Rev. Lett.* **59**, 1663 (1987).
- ¹³Ch. Fattinger and D. Grischkowsky, *IEEE J. Quantum Electron.* **QE-25**, 2608 (1989).
- ¹⁴X.-C. Zhang, B. B. Hu, J. T. Darrow, and D. H. Auston, *Appl. Phys. Lett.* **56**, 1011 (1990).
- ¹⁵X.-C. Zhang, J. T. Darrow, B. B. Hu, D. H. Auston, M. T. Schmidt, P. Tham, and E. S. Yang, *Appl. Phys. Lett.* **56**, 2228 (1990).
- ¹⁶X.-C. Zhang, B. B. Hu, S. H. Xin, and D. H. Auston, *Appl. Phys. Lett.* **57**, 753 (1990).
- ¹⁷D. Krökel, D. Grischkowsky, and M. B. Ketchen, *Appl. Phys. Lett.* **54**, 1046 (1989).
- ¹⁸D. Grischkowsky, Søren Keiding, Martin van Exter, and Ch. Fattinger, *J. Opt. Soc. Am. B* **7**, 2006 (1990).
- ¹⁹M. van Exter, Ch. Fattinger, and D. Grischkowsky, *Opt. Lett.* **14**, 1128 (1989).
- ²⁰F. E. Doany, D. Grischkowsky, and C.-C. Chi, *Appl. Phys. Lett.* **50**, 460 (1987).